

**CONTENT**

**PLUNGER VALVE** ..... 1-4  
PLUNGER VALVE ..... 1

## ORDERING GUIDE

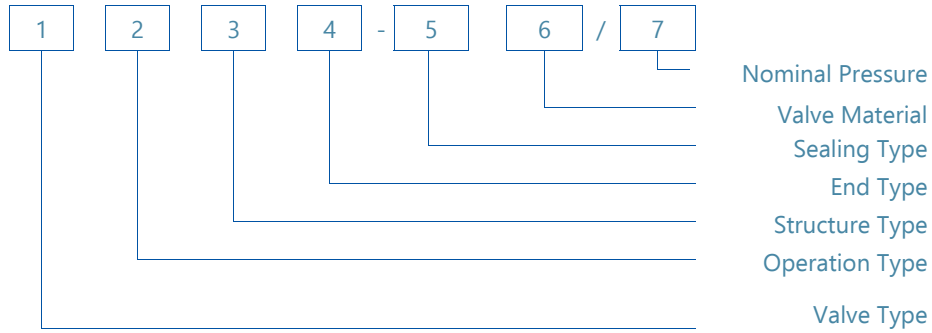

### 1. Valve Type

Type	Vaned Ring Type	Slotted Cylinder Type	Perforated Cylinder Type	Seat Spray Type
Code	N1	N2	N3	N4

### 2. Operation Type

Type	Wormgear	Electric/manual	Pneumatic	Hydraulic
Code	1	2	3	4

### 3. Structure Type

Structure	On/off	Modulating
Code	1	2

### 4. End Type

Type	Flange
Code	1

### 5. Sealing Type

Type	Metal Sealing
Code	1

### 6. Valve Material

Parts	Carbon Iron	Carbon Steel	Alloy Steel	Stainless Steel
Body	B1	B3	B5	B6
Seat	D1	D3	D5	D6
Stem/needle	S1	S3	S5	S6

\*More material specifications are available on request.

### 7. Nominal Pressure

PN	0.6(MPa)	1.0(MPa)	1.6(MPa)	2.5(MPa)	4.0(MPa)
Code	6	10	16	25	40

\*More pressure specifications are available on request.

## ORDERING GUIDE

The plunger valve is designed to meet the regulation purpose in networks. The plunger valves are dropped the effect of cavitation due to the axial movement of the plunger by means of crank gear mechanism. It is ideal for straight-line flow control, in-line energy dissipation, and free-discharge applications, suitable for use in water treatment, water distribution, in dams, power plants, industry and in pressure management.

- Wide range of pressure ratings nominal sizes and designs
- With customized control device depending on operating conditions
- Axial movement of the plunger by means of crank gear mechanism
- With manual operation, electrical/manual operation, hydraulic operation
- With clear mechanical valve opening indicator
- With low actuating torque due to pressure balanced valve piston
- With full open and full close position output signal (Please clarify particularly with manual operation)
- The Modulating type plunger valve with DC4~20mA (Default) or 0~5V valve opening real time output signal
- Combined structure design, throttle components of downstream side can be replaced to accommodate the different working condition

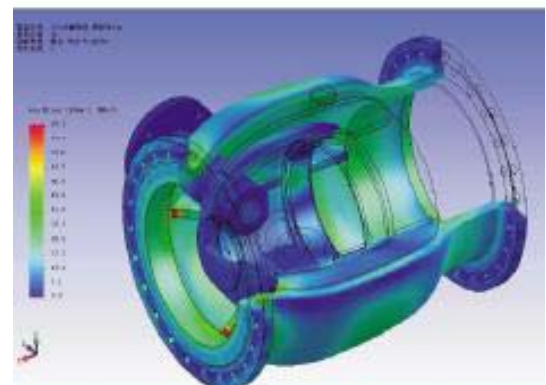
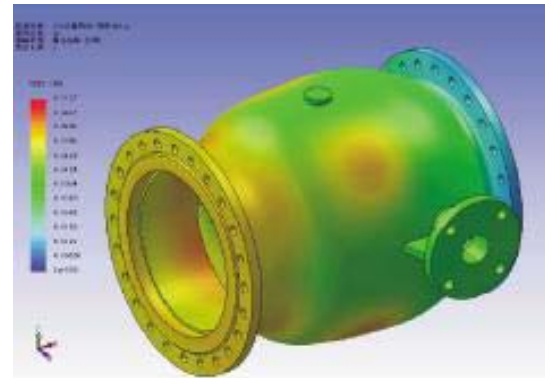

### FEATURE

- Superior linear flow characteristics
- Compact design
- Minimum vibration and noise
- Soft and metal combined seal structure, zero leakage
- Wear-resistant
- corrosion-resistant
- Infiltration-proof piston
- Stainless steel stop pin
- Easy installation and maintenance
- Long operation life



**ORDERING GUIDE**

**APPLICATION**

- Pump start-up and control valve
- Reservoir inlet
- Control device in the bottom outlet valve of dams (with or without venting)
- Control device in the inlet and bypass of turbines
- Safety device in the bypass outlet of turbines for quick opening
- Surge anticipating device in pumping or pressurized systems

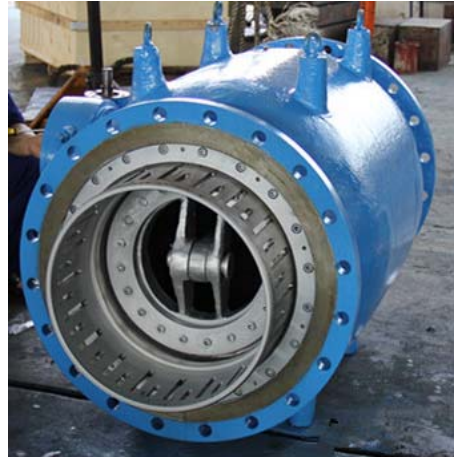

**PARTS LIST & MATERIAL**

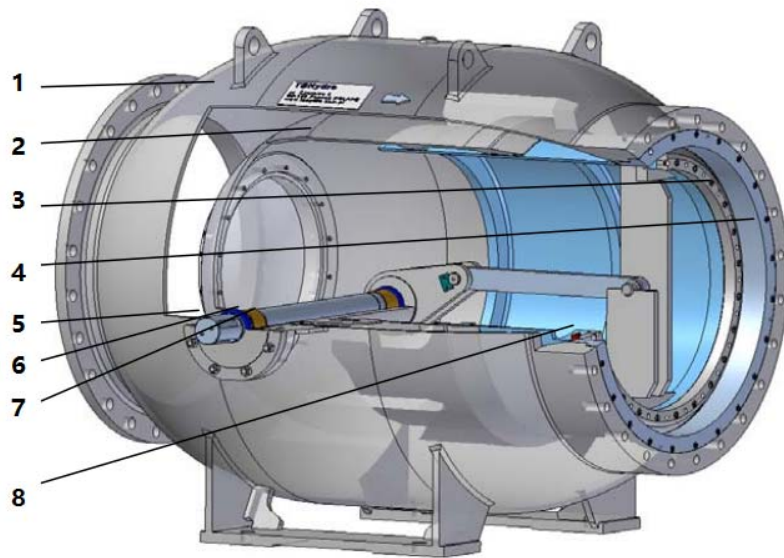

Item	Parts Name	Material (standard)
1	Body	Ductile Iron / Carbon Steel / Stainless Steel
2	Plunger	Stainless Steel
3	Clamping Ring	Ductile Iron / Carbon Steel
4	Ring	Ductile Iron / Carbon Steel
5	Shaft	Stainless Steel
6	Seals	Buna-N/EPDM + Metal
7	Bushing	Bronze / Self-lubricating
8	Main Sealing	Buna-N/EPDM + Metal

\*More material specifications are available on request.

**ORDERING GUIDE**

**PRINCIPLE**

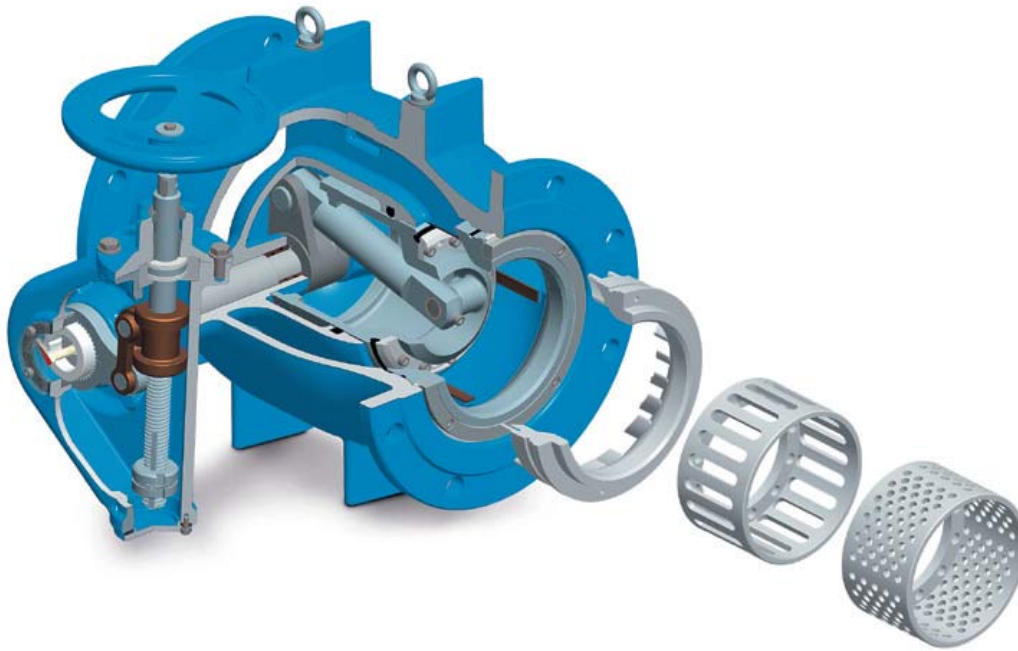

The valve body is double layer structure (inner and outer cylinder), crank mechanism converts rotation of the valve shaft to axial movement of the plunger along the guide rail which change the flow area between plunger and valve seat so that control the flow or pressure.

There is tapered hole or groove on the cylinder, which is symmetrical uniformly distributed, the medium flows through the hole or groove becomes multi-strand high speed fluid, jetting from outer to inner of cylinder and impinging in the center of the pipeline, therefore, cavitation is limited in the center of plunger and pipeline, won't damage the valve and pipeline as cavitation, according to the specific site working condition, we design four basic types as stated in the following.



**ORDERING GUIDE**

**TECHNIQUE DATA**

Type	I - Taper Hole Regulation	II - Groove Regulation	III - Fan Blade Regulation	IV - Seat Regulation
Advantage	<ul style="list-style-type: none"> <li>-High control precision</li> <li>-Extreme pressure differential condition</li> <li>-Optimum prevention of cavitation</li> </ul>	<ul style="list-style-type: none"> <li>-High control precision</li> <li>-High pressure differential condition</li> <li>-Medium containing suspended solids</li> <li>-Prevention cavitation</li> </ul>	<ul style="list-style-type: none"> <li>-Normal pressure differential condition or high back pressure in the down stream</li> <li>-Medium containing much suspended solids</li> <li>-As pump start-up valve with sufficient back pressure</li> </ul>	<ul style="list-style-type: none"> <li>-Gas adjustment</li> <li>-Low pressure differential condition</li> <li>-Medium containing much suspended solids</li> <li>-As pump start-up valve with sufficient back pressure</li> </ul>
DN	Flow Resistance Coefficient (at full open position)			
150	-	7.3	2.4	1.6
200	-	7.6	1.6	1.3
250	8.1	8.5	2.5	1.9
300	7.8	7.6	1.9	1.4
350	7.6	6.5	1.5	-
400	7.6	6.5	1.5	-
450	7.6	6.5	1.5	-
500	7.6	6.5	1.5	-
600	7.6	6.5	1.5	-
700	7.6	6.5	1.5	-
800	7.6	6.5	1.5	-
900	7.6	6.5	1.5	-
1000	7.6	6.5	1.3	-
1200	7.6	6.5	1.1	-
1400	7.6	6.5	1.1	-
1600	7.6	6.5	1.0	-
1800	7.6	6.5	1.0	-

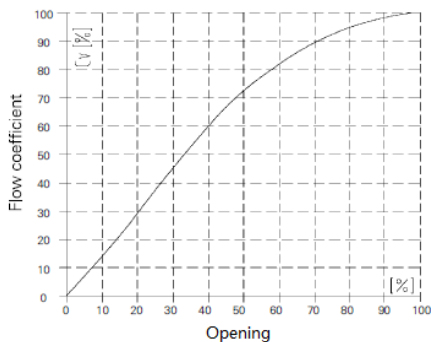

Characteristic Curve

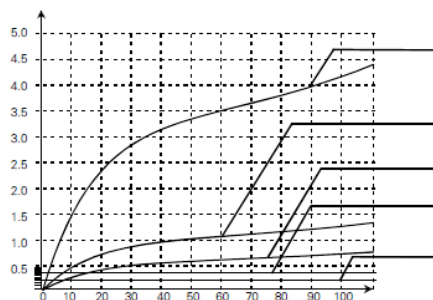

Cavitation Coefficient

Butterfly valve

Type IV

Type III

Type II

Type I



**ORDERING GUIDE**

**DIMENSION**

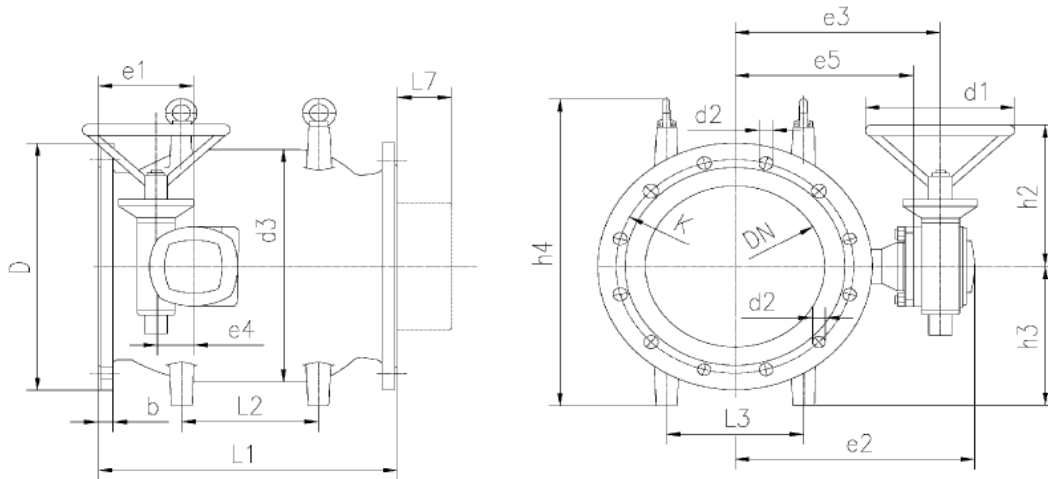

DN	L1	L2	L3	L7	d1	d3	e1	e2	e3	e4	h2	h3	h4
150	350	130	140	48	250	236	130	328	270	63	265	155	355
200	400	130	140	68	250	302	150	328	270	63	265	190	425
250	450	170	170	83	250	371	145	403	345	63	265	230	513
300	500	230	230	94	250	434	160	403	345	63	265	260	573
400	600	300	300	127	250	575	170	518	467	80	268	335	741
450	650	350	350	144	250	632	150	518	467	80	268	345	761
500	750	400	400	153	400	711	175	629	550	100	439	385	841
600	900	500	500	150	400	840	280	654	575	100	449	460	1010
700	1050	560	560	195	400	998	315	800	725	125	454	520	1150
800	1200	600	600	244	400	1127	400	797	725	125	454	600	1309
900	1350	700	700	275	400	1258	420	880	800	160	520	650	1428
1000	1500	750	750	292	400	1380	460	1016	898	160	520	720	1568
1200	1800	800	800	363	400	1645	560	1136	1040	200	600	850	1828
1600	2500	1200	1200	480	600	2245	725	1610	1490	250	970	1200	2610
1800	2700	1500	1500	590	600	2525	840	2000	1715	315	1200	1380	3060
2000	3000	1600	1600	620	600	2800	900	2210	1925	315	1200	1540	3410

\*More dimension specifications are available on request.